



# **DELANO**

pickup systems



INSTALLATION GUIDE

## Index

Pickup mounting .....	05
Shielded 1-conductor cable wiring .....	06
2-conductor cable wiring.....	07
4-conductor cable wiring .....	08
The Hybrid series installation .....	11
Sonar series electronics installation .....	15
Sonar series electronics switching .....	18
Marking of conformity.....	19
Contact information .....	20



## Dear Customer,

We are pleased that you have selected one of our products, and are sure it is the right decision if you value uncompromising sonic performance of your instrument. Delano products combine highest quality materials with an experience in building pickups and electronic circuits for musical instruments of over 30 years. As a result you receive a fine piece of craftsmanship containing outstanding features and modern improvements developed and manufactured by our small team of experts. As an owner of a Delano product you can be self-assured in the knowledge that you have the finest available.

This small brochure contains all required information for the installation of the enclosed Delano product, so please read the following instructions carefully. If you need more information please contact your authorized Delano dealer or get in touch with us directly.

Delano Pickup Systems, November 2011

Reinhard Jedamzik



## Pickup mounting

for DELANO PC series pickups and DELANO The Xtender D series pickups

### Mounting of Delano two-section pickups

4-string bass: Every section is centered under the outer 2 strings.

- section a) is centered under the E-A strings
- section b) is centered under the D-G strings

5-string bass: Every section is centered under the outer 3 strings.

- section a) is centered under the B-E-A strings
- section b) is centered under the A-D-G strings

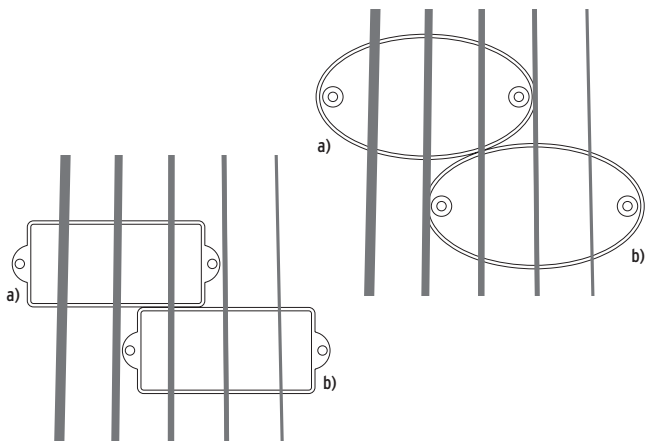

## shielded 1-conductor cable wiring

for DELANO shielded 1-conductor wired pickups  
The colors of DELANO wires are: black = hot, shielding = gnd

### active operation:

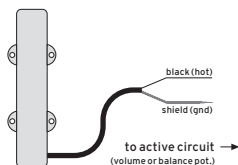

### passive operation: 1 pickup (vol./tone)

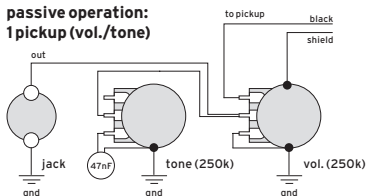

### passive operation: 2 pickups (vol./balance/tone)

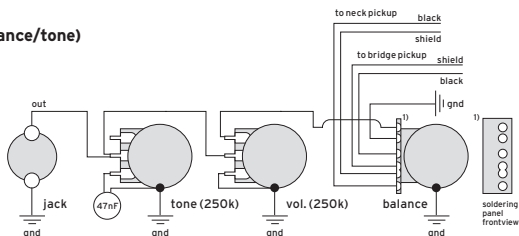

### passive operation: 2 pickups (vol./vol./tone)

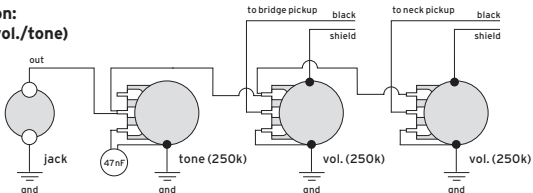

## 2-conductor cable wiring

for DELANO 2-conductor wired vintage pickups in passive operation  
The colors of DELANO wires are: white = hot, black = gnd

### 2 pickups (volume/volume/tone)

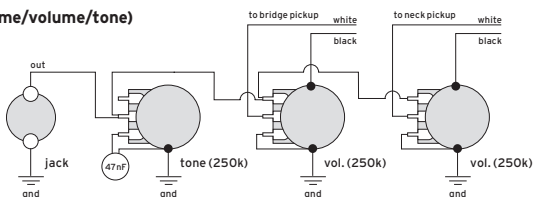

### 2 pickups (volume/balance/tone)

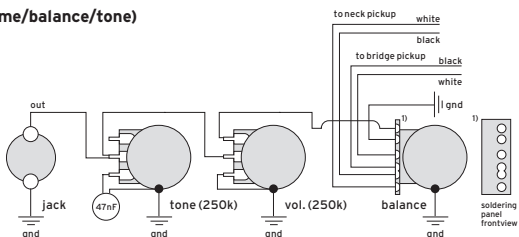

### 1 pickup (volume/tone)

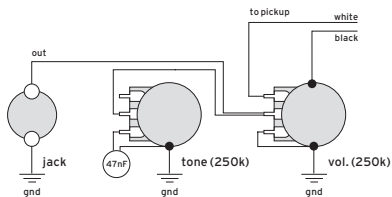

## 4-conductor cable wiring

for DELANO 4-conductor wired pickups

The colors of DELANO wires are: white, green, brown, yellow, ground (gnd)  
(These diagrams do NOT provide "TheHybrid" pickup installation)

### series / single coil\*

mini toggle switch (on/on/on)

#### series:

green = hot out  
brown = gnd  
white, yellow (connect)

#### single coil:

green = hot out  
white, brown, yellow = gnd

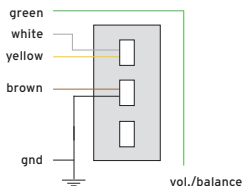

\*) This diagram causes **series/P-bass® type (cross coils in series)** switching with **SBC HE/S-4 type pickups**.

### series / single coil / parallel\*

mini toggle switch (on/on/on)

#### series:

green = hot out  
brown = gnd  
white, yellow (connect)

#### single coil:

green = hot out  
white, brown, yellow = gnd

#### parallel:

white, green = hot out  
brown, yellow = gnd

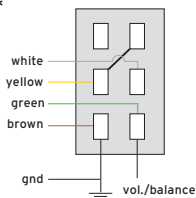

or:

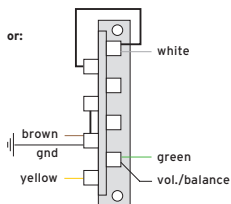

\*) This diagram causes **series/P-bass® type (cross coils in series)/parallel** switching with **SBC HE/S-4 type pickups**.

## 4-conductor cable wiring

for DELANO 4-conductor wired pickups

The colors of DELANO wires are: white, green, brown, yellow, ground (gnd)  
(These diagrams do NOT provide "TheHybrid" pickup installation)

### single coil (rear coil) / series / single coil (front coil)\*

mini toggle switch (on/on/on)

#### single coil (front):

white = hot out  
brown = gnd  
green, yellow (connect)

#### single coil (rear):

green = hot out  
white, brown, yellow = gnd

#### series:

green = hot out  
brown = gnd  
white, yellow (connect)

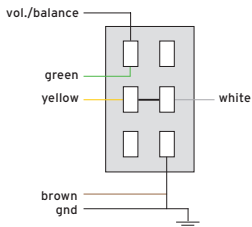

\*) This diagram causes P-bass® type (cross coils in series)/series/reversed P-bass® type (cross coils in series) switching with SBC HE/S-4 type pickups.

### single coil (rear coil) / parallel / single coil (front coil)\*

mini toggle switch (on/on/on)

#### single coil (front):

white = hot out  
green, brown, yellow = gnd

#### single coil (rear):

green = hot out  
white, brown, yellow = gnd

#### parallel:

white, green = hot out  
brown, yellow = gnd

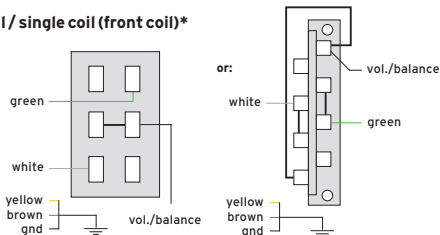

\*) This diagram causes P-bass® type (cross coils in series)/parallel/reversed P-bass® type (cross coils in series) switching with SBC HE/S-4 type pickups.

## DELANO® THE HYBRID SERIES

An uncompromising pickup that combines in one single construction the two most legendary sounds in bass history!

### Part 1: J-Bass™

Single coil bridge pickup with the immortal characteristics of early 60's pickups. AlNiCo 5 magnet coil body made of vulcanized fiber and gauge 42 wire.

### Part 2: Sting Ray™ Humbucker

Low resistance neck coil with 9.5 millimeter AlNiCo 5 magnets. Authentic sound guaranteed in this setting too, thanks to the special engineered bridge J-coil: the second MM™-coil is integrated inside.

### Switching concept:

The integrated switch manager lets you get both of these great classic sounds at the touch of a toggle, each one reconstructed exactly in its original form with all its strengths and nuances of character: Passive function in single-coil mode, active function with the DELANO BED 2- or 3-band EQ activated in Humbucker mode. The internal switching of the pickup is lightning fast, too!

For maximum sound authenticity we recommend the custom neck version of our J™-single coil JC4AL/H or JC5AL/H for the neck position. With both pickups switched on, this JJ-arrangement typically produces a noise-free output.

### No trouble with treble:

The 'Hybrid' set includes a specially designed treble pot that works as a typical passive tone control for the J™-sounds in the passive mode and doubles as the active treble EQ in the Sting Ray™ setting. The neutral setting is located conveniently in the middle position; when switching, it's easy to get the basic settings you need.

### Additional features:

In the humbucking mode - we call it 'Ray' mode - you're able to combine the hybrid pickup with the neck pickup, too. This is an additional feature. But take note, that use of the neckside single coil pickup typically causes hum, if driven with the active electronics. To achieve an authentic 'Ray' sound, you should turn the balance knob fully backwards - and so your bass is hum-free.

## "The Hybrid" Series wiring for 2 pickups, & 2 volume pots

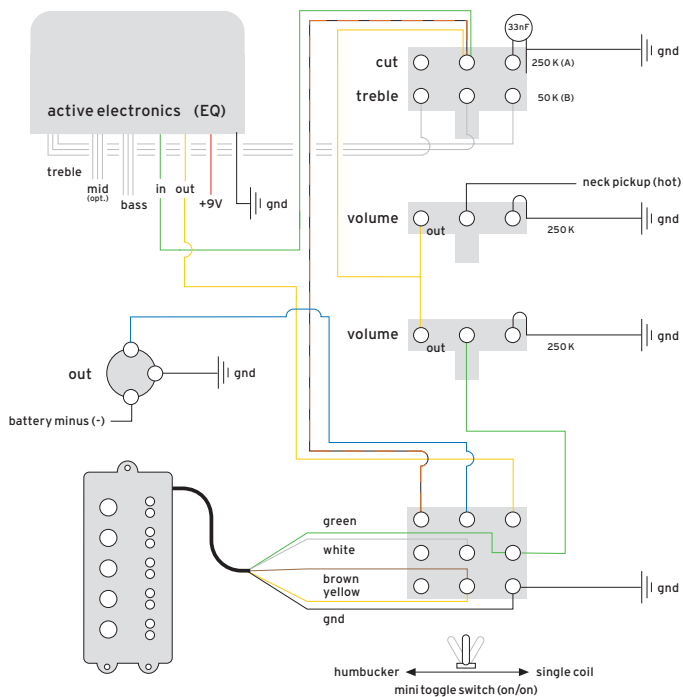



## "The Hybrid" Series wiring for 1 pickup, & volume pot

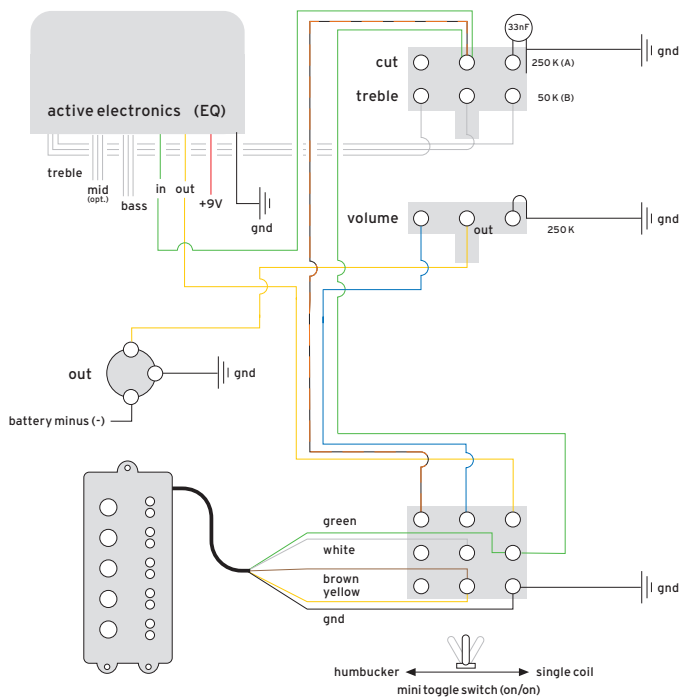

## DELANO® SONAR SERIES

Scaling new heights in perfecting the tonal capabilities of magnetic pickups, the Delano Sonar bass preamp series is designed for just one purpose:  
**Making a good tone even better.**

As an integral part of any active bass guitar, an active EQ has to fulfill countless requirements regarding strength and clarity in tone, power consumption and installation. To meet this challenge perfectly, the time has come for a new onboard preamp: Sonar. This smart powerhouse delivers the real thing: rocksteady bottom, cutting midrange and naturally brilliant high end. Whether adapting its tone to match the surrounding acoustics, enhancing versatility or increasing your musical expression, this preamp always feels like a natural extension, preserving all the benefits of passive operation: uncoloured, true and focused sound. Comparing the flat-set sound to bypassed full passive action you'll detect no difference. Matchless. And with its perfectly matched band-pass filters and separated amplifier stages, adjustments stay predictable at any time without overpowering tone.

The Delano Sonar onboard preamp is housed in a sealed slim-box, which provides easy, space-saving installation and secure insulation to other electrical components. Its minimal power consumption lets you forget where your battery-box is - make a guess?

Availability:  
**SONAR 2** / 2-Band  
**SONAR 3** / 3-Band  
**SONAR 3 MS** / 3-Band  
**SONAR 3 MS/E** / 3-Band

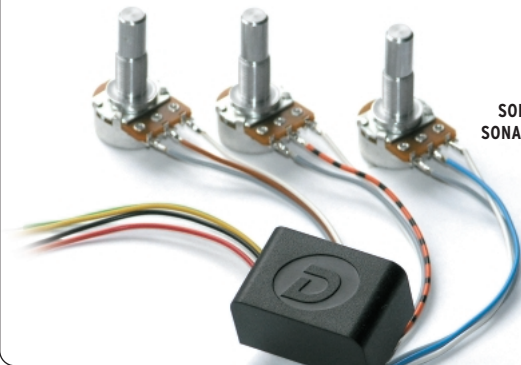





## active electronics switching

for SONAR 3 MS & SONAR 3 MS/E EQs

The SONAR 3 MS and 3 MS/E 3band EQs offer the great advantage of selecting different mid frequencies.

SONAR 3 MS = mid selection onboard, SONAR 3 MS/E = mid selection with three-position toggle switch

### SONAR 3 MS

Select mid frequencies onboard as follows:

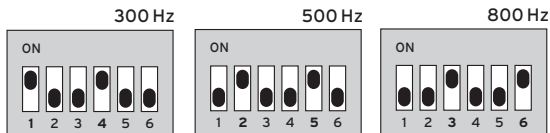

### SONAR 3 MS/E

Select mid frequencies with three-position toggle switch as follows:

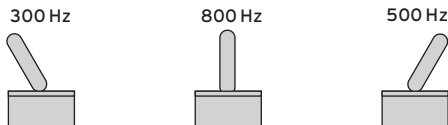

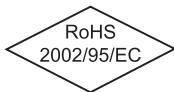

The crossed out dustbin implies, that all products that are subject to the ElektroG may not be disposed in the domestic waste at the end of it's working life. It must be taken to a special local authority waste collector differentiated waste collection center. The avoidance and recycling of waste products saves materials, as does the purposeful economical handling of raw materials.

Delano products are registered under WEEE No. DE 58703363

Parts are made by Reinhard Jedamzik, DELANO Pickup Systems, and are not to be represented a product of the following companies:

- EMG is a registered trademark of EMG, Inc.
  - Precision Bass, Jazzbass and Fender, JB Pickup, J-Bass, P-bass are registered trademarks of Fender Musical Instrument Corporation.
  - Bartolini pickups is a registered trademark of Bartolini, Inc.
  - Musicman, Stingray, MM pickup, B 00 series is a registered trademark of Ernie Ball, Inc.
- Delano is not affiliated with these companies.

The trademarks, logos, and service marks (collectively the "Marks") listed are trademarks of the Company and/or its affiliates. Any other Marks used are trademarks of their respective owners. The mention of or reference to any company or product is not a challenge to the trademarks or copyrights concerned.

All parts have a limited warranty against defects in material and workmanship. Prices, specifications and policies are subject to change without notice.

## **DELANO Pickup Systems**

Reinhard Jedamzik

Surmannskamp 7 · 45661 Recklinghausen · Germany  
phone:++49-(0)2361-653215 · fax:++49-(0)2361-183473

[www.delano-pickups.com](http://www.delano-pickups.com)